

Weather proof box camera housing with IP67 standard



- IP67
- Empty housing
- Adjustable sliding camera tray & sealed cable entry glands
- Fully-cable management system with swivel bracket
- Pressure die-coast aluminum alloy construction

## Specification

<b>Model Name</b>	<b>CASH132E</b>
<b>Temper Glass Thickness</b>	2 mm
<b>Camera Installation Space (W × H × L)</b>	110 × 70 × 250 mm
<b>Dimension (W × H × L)</b>	145 × 110 × 375 mm
<b>Net Weight</b>	2.38 kg
<b>Packing</b>	6 pcs/cn; 2.8 cuft
<b>Carton (W × H × L)</b>	467 × 394 × 409 mm
<b>Weatherproof</b>	IP67
<b>Certifications</b>	CE, FCC, RoHS

\*Design and specifications are subject to change without prior notice.

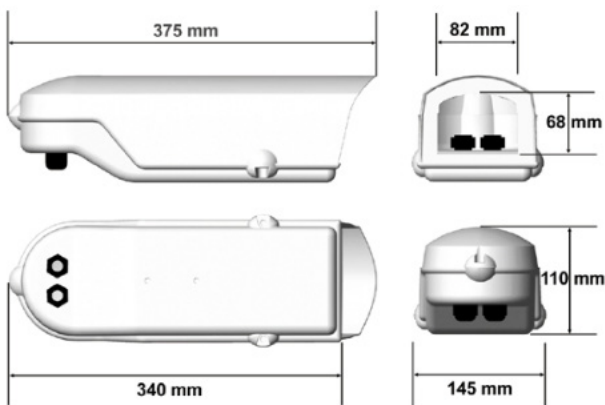

**MAXIMUM INTERNAL DIMENSIONS**  
250mm Length x 110mm Width x 70mm Height