

long distance overviews & license plate capture camera



- 1/3" SONY CCD/DSP
- 600TV lines
- fog penetration
- scheduled ICR day/night switching
- headlight suppression
- Wide Dynamic Range
- 3D DNR, intelligent traffic mode
- vandal-proof
- IP67

## Specification

<b>Signal system</b>	NTSC	PAL
<b>Imaging area</b>	4.9mm x 3.7mm	
<b>Image pickup device</b>	SONY 1/3" Super HAD II Hi-Res CCD	
<b>Effective pixels(HxV)</b>	768 x 494	752 x 582
<b>Electric</b>		
<b>Scanning system</b>	2:1 Interlace V: 59.94Hz H: 15.734KHz	2:1 Interlace V: 50Hz H: 15.625KHz
<b>Sync system</b>	Internal / line lock (AC input only)	
<b>Horizontal resolution</b>	600 / 700 TV lines (day/night mode)	
<b>Infrared illuminator</b>	70M distance, 850nm wavelength, view angle of 50 degree	
<b>LEDs</b>	Superior power: 96 pcs LEDs; Metaphase-type LEDs, high-efficient array	
<b>Gamma correction</b>	10 levels selectable	
<b>Minimum illumination</b>	Day mode: 0.01 Lux(F1.4, AGC on , 10IRE); 0.04 lux (F1.4, AGC on , 50IRE) Night mode: 0.003 Lux(F1.4, AGC on , 10IRE); 0.01 lux (F1.4, AGC on , 50IRE)	
<b>S/N ratio</b>	More than 50dB (AGC off)	
<b>Built-in Lens</b>	f:7.5-50mm F1.3, IR-corrected (DC Lens)	
<b>Privacy zone</b>	On / Off, up to 8 zones	
<b>Day/Night mode</b>	Auto / Mono / Color / D/N Sync / Schedule	
<b>Iris control</b>	Video / DC driver	
<b>Lumii</b>	9 levels selectable	
<b>White Balance</b>	ATW1 / ATW2 / Manual	
<b>Electric shutter</b>	Auto ( 1/60 to 1/100K sec.) / manual 46 stpes (1/60 to 1/100K sec.)	Auto ( 1/50 to 1/100K sec.) / manual 46 stpes (1/50 to 1/100K sec.)
<b>BLC</b>	BLC1 /BLC2 /BLC3 /BLC4 /BLC5 /BLC6 / Off	
<b>Aperture control</b>	High / Mid / Low	
<b>Chroma</b>	9 levels selectable	
<b>OSD</b>	Yes	
<b>Intelligent traffic mode</b>	1. Traffic 1 : 20 to 110 km/hr (12 to 68 mph) 2. Traffic 2: 90 to 180 km/hr (56 to 112 mph) 3. Traffic 3 : 20 to 110 km/hr (12 to 68 mph) 4. Traffic 4: 0 to 20 km/hr (0 to 12 mph)	
<b>Headlight suppression</b>	10 levels selectable	
<b>Fog penetration</b>	6 levels selectable	

† Product specifications and features are subject to change without prior notification.

Tailored Solution International Co., Ltd.

E-mail: sales@tsict.com, http://www.tsict.com

<b>WDR</b>	On / Off		
<b>Digital Noise Reduction (DNR)</b>	Off/ 2DNR/ 3DNR		
<b>Mirror</b>	On / Off		
<b>Flickerless</b>	On / Off		
<b>Remote control</b>	Yes (RS485)		
<b>Video output</b>	1Vpp composite output, 75 ohm		
<b>Mechanism</b>			
<b>Dimension (L x W x H)</b>	422 x 174 x 145mm (16.6" x 6.9" x 5.7")		
<b>Enclosure</b>	Vandal-proof, side opening, IP67, vandal-proof, die-cast aluminum with stainless screw, salt resistance, with wall mount cable management bracket		
<b>Weight</b>	6 kg (13.22 lb)		
<b>Application</b>	Ceiling mount/Corner mount/Pole mount		
<b>Environment</b>			
<b>Operating temperature</b>	-30 °C ~ 50 °C		
<b>Operating humidity</b>	30% ~ 90% RH		
<b>Storage temperature</b>	-30 °C ~ 60 °C		
<b>Protection Class</b>	IP66/IP67		
<b>Power supply</b>			
<b>Power requirement</b>	AC24V	AC90 ~ 260 V	AC24V
<b>Power consumption</b>	45W (max. with heater&blower)		
<b>Ordering Information</b>	MSL221-HN2	MSL221-HN7	MSL221-HP2

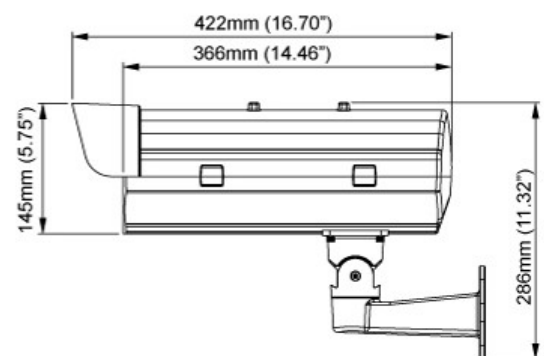

- 1/3" Sony CCD
- 600 TVL
- Fog Penetration
- Wide Dynamic
- 3D DNR
- Light Suppression
- 0.003 Lux min. illumination
- Privacy Zone
- D/N
- ICR
- Color
- B&W
- OSD